



**Einbauanleitung Elektrosatz
Anhängervorrichtung mit 13-P Steckdose
lt. DIN/ISO Norm 11446**

**Instructions de montage du faisceau
électrique pour crochet d'attelage
conforme à la norme
DIN/ISO 11446 prise 13-P**

**Fitting instructions electric wiringkit
towbar with 13-P socket up to
DIN/ISO norm 11446**

**Montage-handleiding elektrokabelset voor
trekhaak met 13-P contactdoos
vlg. DIN/ISO norm 11446**

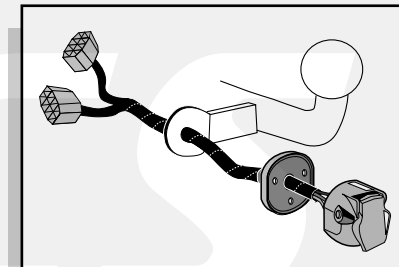

SKODA SUPERB 2002-

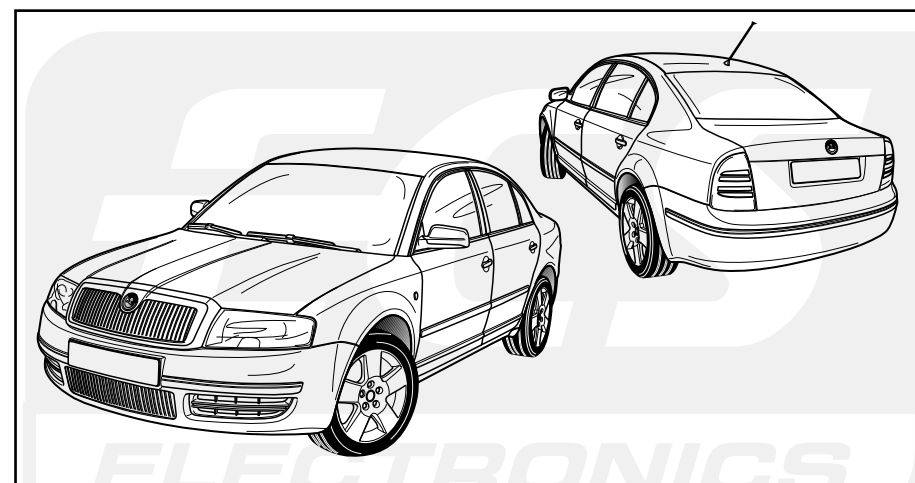

Bestel Nr.: SK-004-DL

* Teilliste

* Liste de pieces

* Part list

* Onderdelenlijst

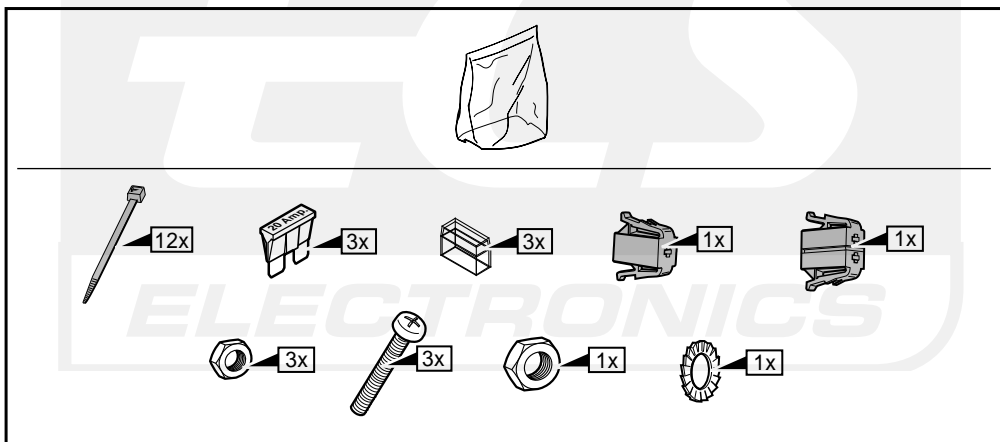
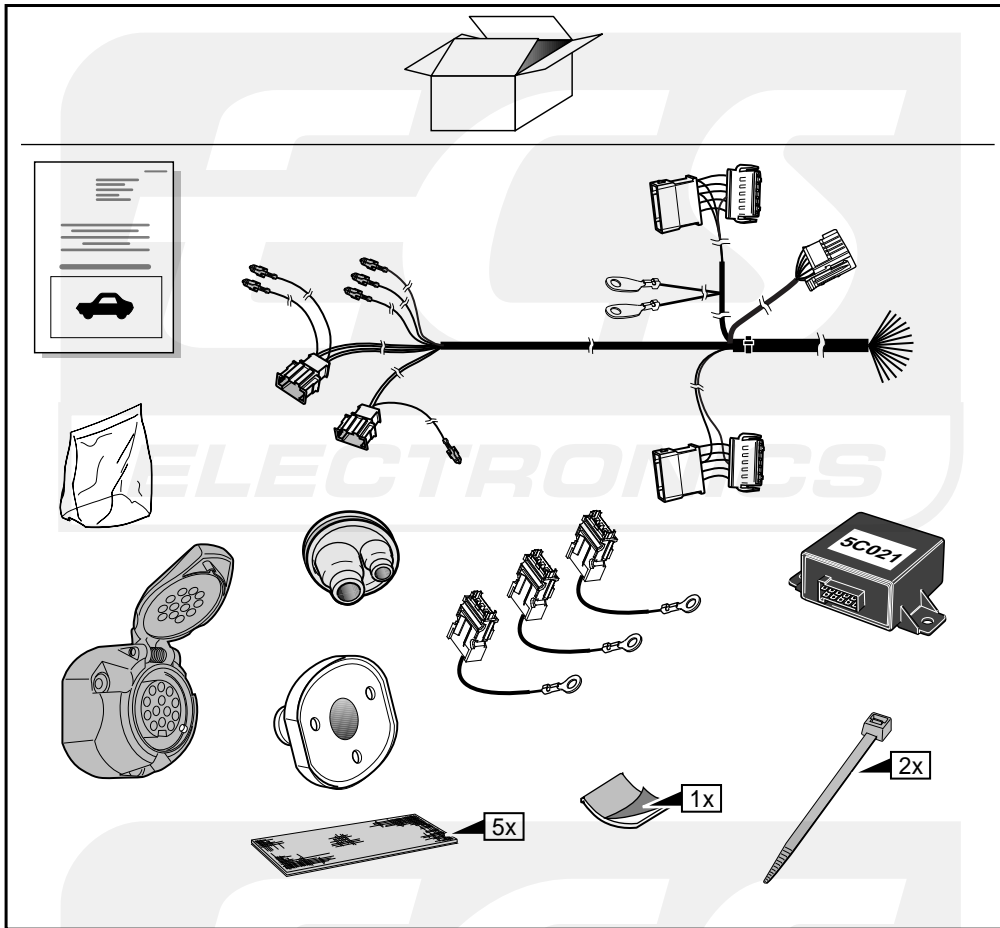

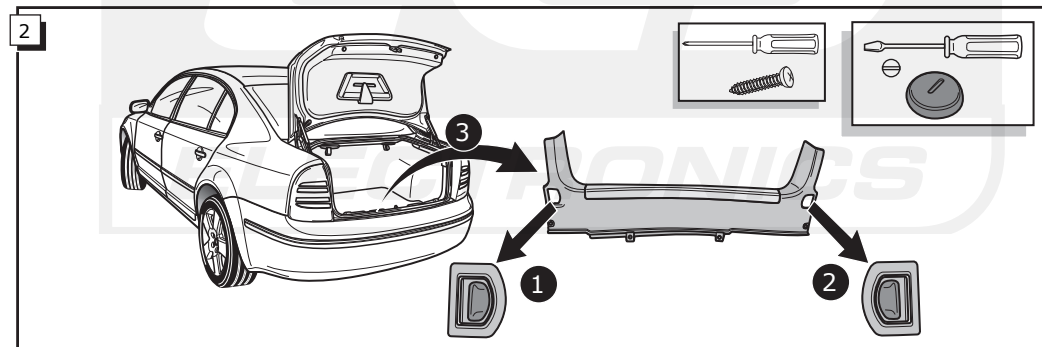
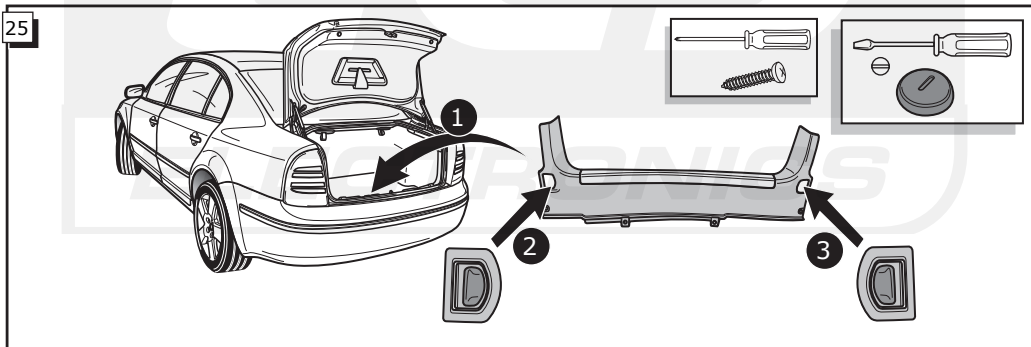
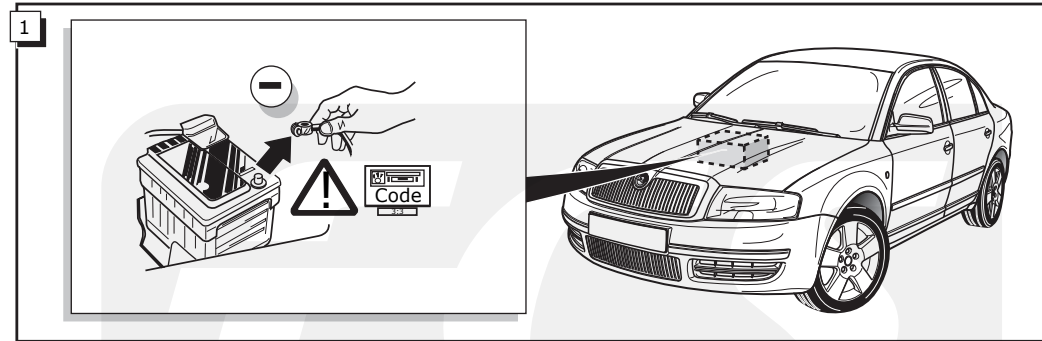
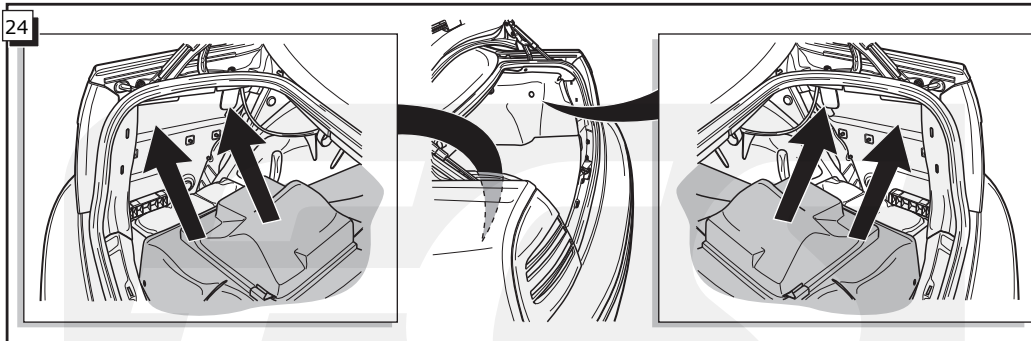

INFO *Die Wirkung des C2-Steuergeräts kann mittels des Anschlusses des Anhängers (oder Testkasten mit 21W Lampen) und der Anschaltung des Blinkgebers mit einem ausgedrehten Blinklicht geprüft werden. Die andere Blinklichter blinken dann schneller. (Achtung: Ein Testkasten wo ausschließlich LED's als Belastung verwendet werden, kann hierfür nicht verwendet werden).

*Le fonctionnement du module C2 peut être contrôlé en branchant une remorque/caravane (ou boîte test avec des lampes 21W) et en indiquant une direction avec une lampe clignotante dévissée. Les autres lampes clignotantes clignotent alors plus rapidement. (Attention: une boîte test où ne sont utilisés que les témoins de contrôle comme charge, ne peut être utilisé dans ce cas.)

*The functioning of the C2-module can be tested by connecting the trailer/caravan (or a test-box with 21W lamps) and switching on the indicator lights with a removed indicator light. The other indicator lights will flash quicker. (ATTENTION: a test-box on which only LED's are being used, can not be used in this case.)

*De werking van de C2-module kan getest worden door een aanhanger (of testkast met 21W lampen) aan te sluiten en met een losgedraaid knipperlicht richting aan te geven. De andere knipperlichten knipperen nu snel. (LET OP: een testkast waar uitsluitend LED's als belasting gebruikt worden, kan hiervoor niet worden gebruikt.)

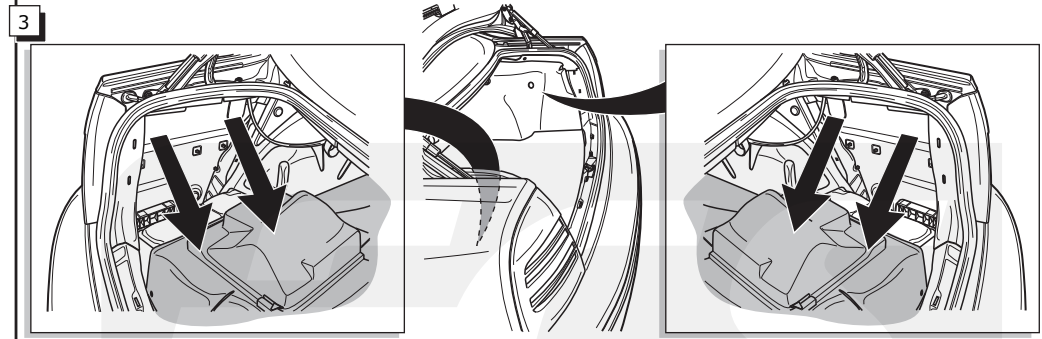

INFO

Die Batterie des Zugfahrzeuges bzw. gezogenen Fahrzeugs nicht über die Steckdose aufladen.

Ne chargez pas les batteries du véhicule tracteur et/ou tracté via la prise de courant.

De accu van het trekkend voertuig c.q. getrokken voertuig niet via de contactdoos opladen.

Do not charge the battery of the towing vehicle and/or towed vehicle via the socket.

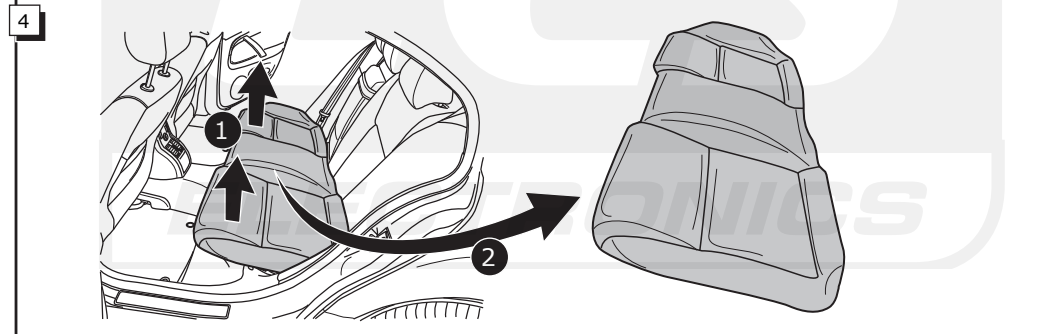

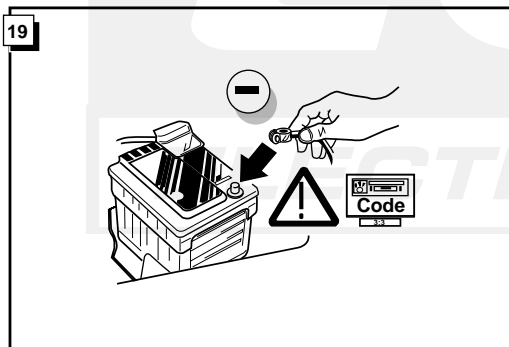
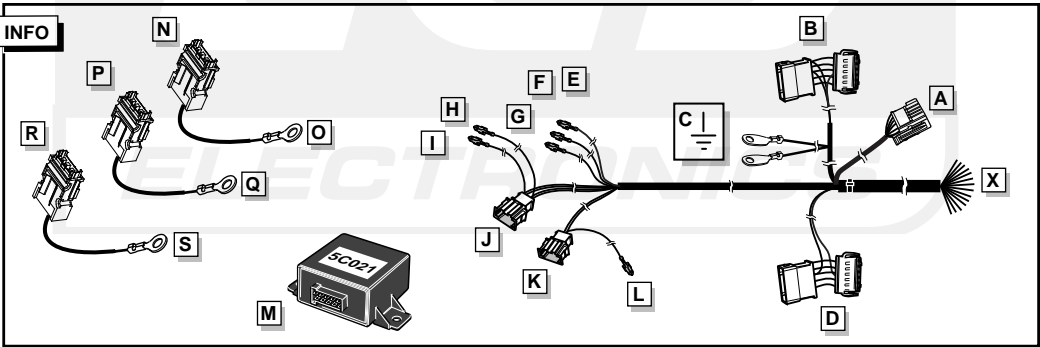
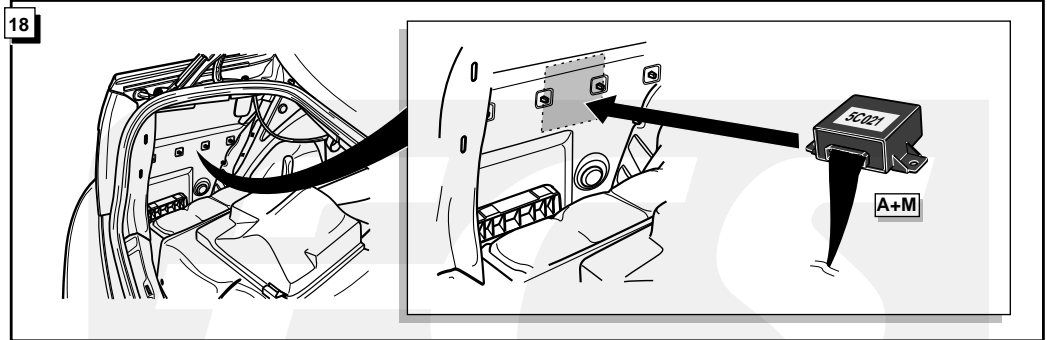
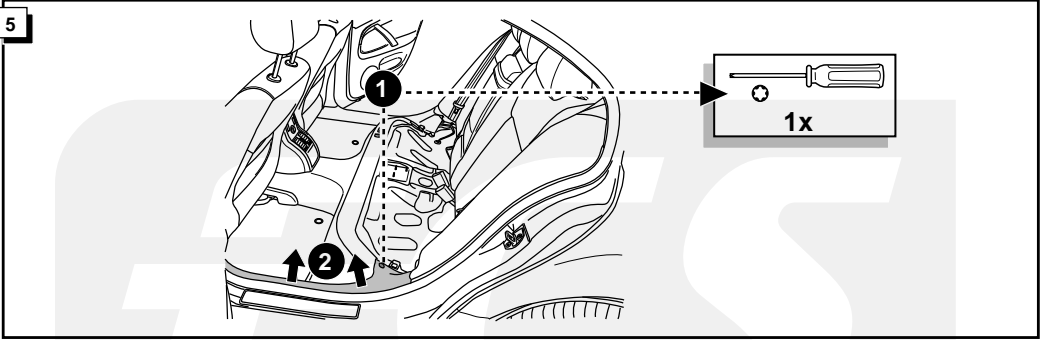

20

**! FUNKTIONEN KONTROLIEREN !
 CONTRÔLER LES FONCTIONS !
 CHECK FUNCTIONS !
 CONTROLER FUNCTIES !**

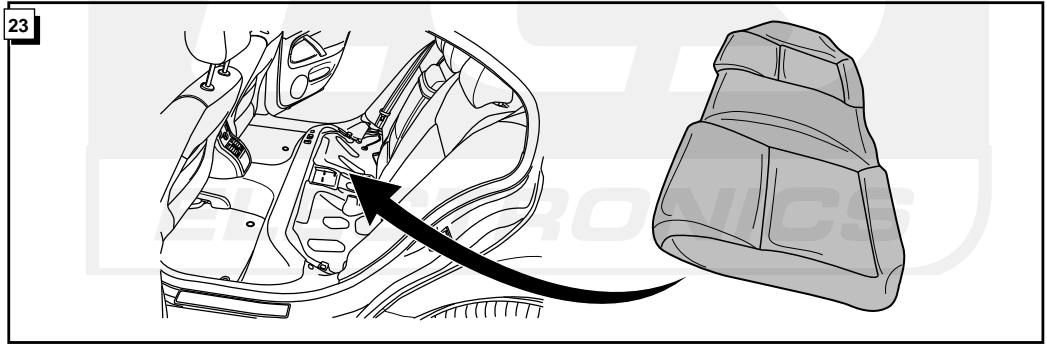
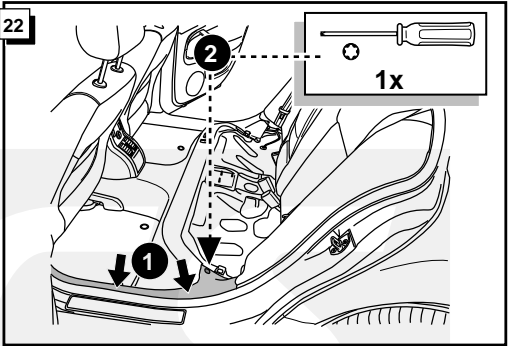
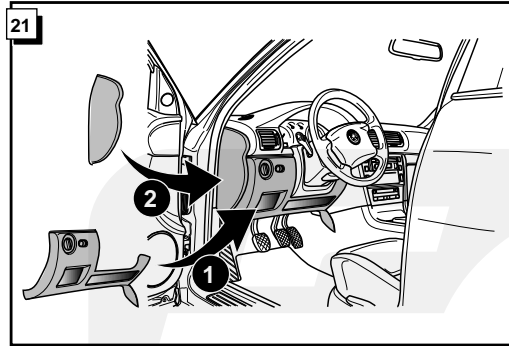
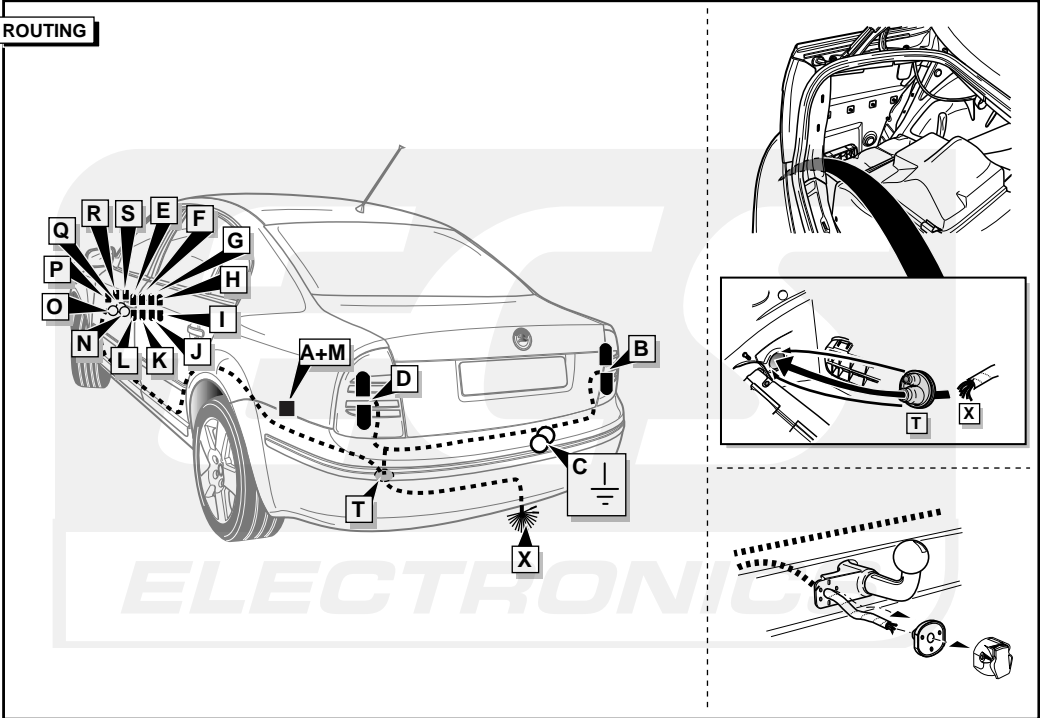

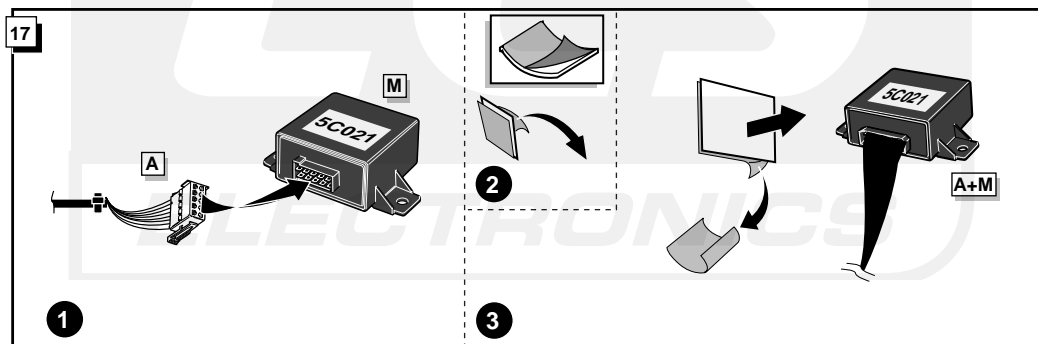
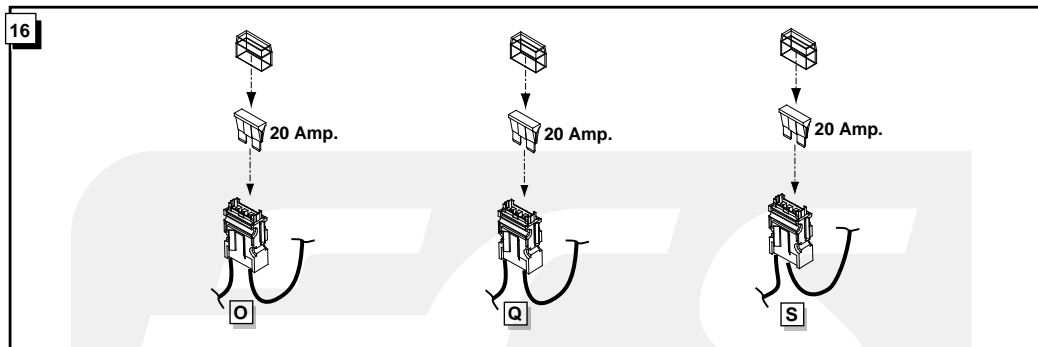
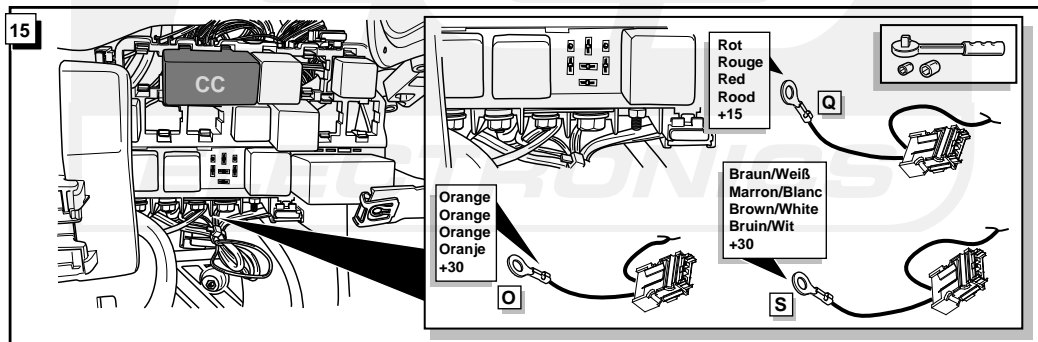
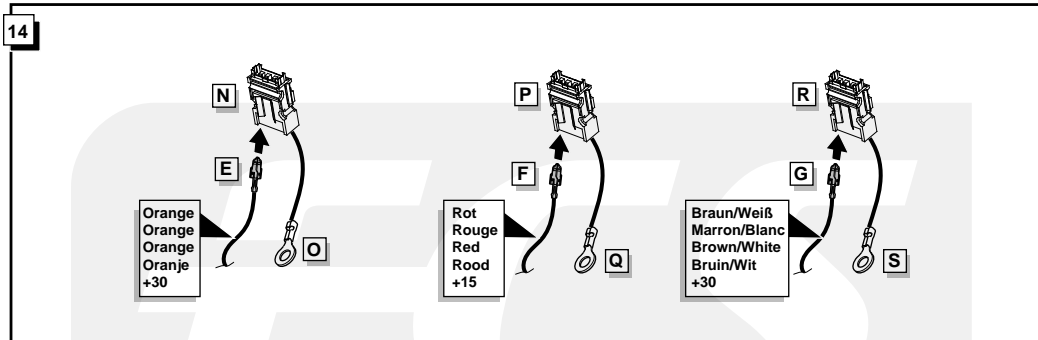

6

Anschluß Steckdose / Connection de la prise / Socket connection / Contactdoos aansluiting

INFO						
DIN/ISO 11446		D	F	GB	NL	Pmax
	1/L	gelb	jaune	yellow	geel	21W
	2	blau	bleu	blue	blauw	2x21W
	1-8	weiß	blanc	white	wit	
	4/R	grün	vert	green	groen	21W
	5/58-R	braun	marron	brown	bruin	52W
	6/54	rot	rouge	red	rood	3x21W
	7/58-L	schwarz	noir	black	zwart	52W
	8	schwarz/rot	noir/rouge	black/red	zwart/rood	2x21W
	9	braun/weiß	marron/blanc	brown/white	bruin/wit	180W / 15 Amp
	10	rot	rouge	red	rood	180W / 15 Amp
	11	weiß	blanc	white	wit	
	12	rot/blau	rouge/bleu	red/blue	rood/blauw	
	13	weiß	blanc	white	wit	

